

# ÓMEGAS ESTRUTURAIS

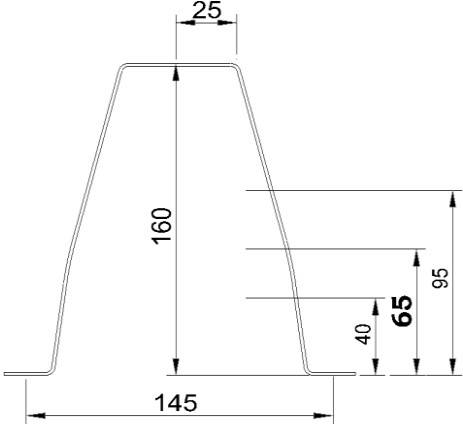
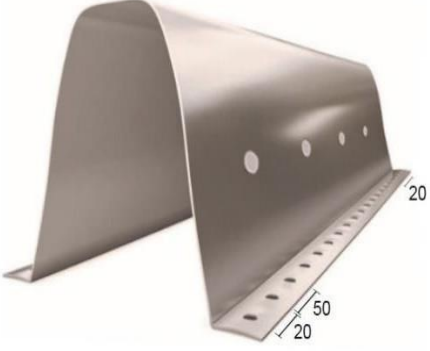
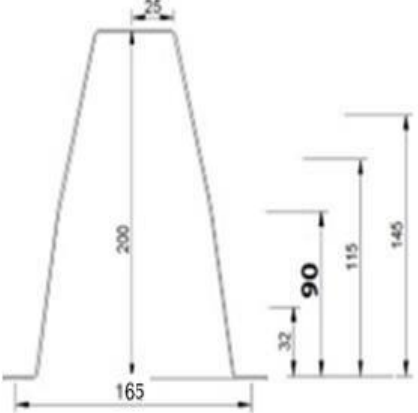
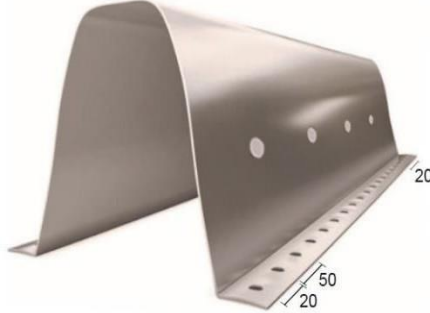
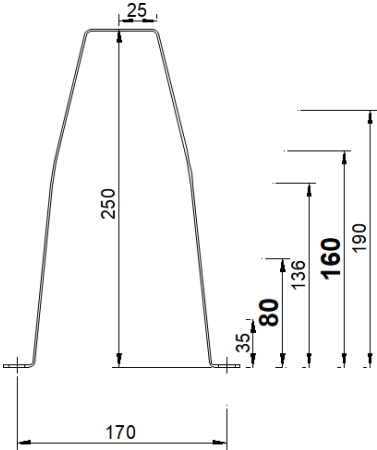
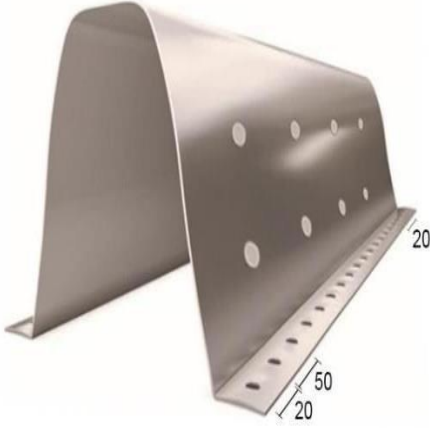

## CONTINUOUS DRILLING SYSTEM

DESIGNATION	PROFILE 2D	PROFILE 3D
Ω80		
Ω100		
Ω120		
Ω140		

DESIGNATION	PROFILE 2D	PROFILE 3D
Ω160		
Ω200		
Ω250		

\* On the Ω160, Ω200 and Ω250 Profiles, the value in bold is the standard hole, but the other hole sizes can be used.

Note:

-  Omega length in multiples of 50mm;
-  Standard drilling 20mm from the start/end of the omega and the rest in multiples of 50mm;
-  Maximum of 6 holes on the transverse.